



Canoes, subsistence and conservation in the Louisiade Archipelago of Papua New Guinea

Mark Smaalders¹ and Jeff Kinch²

“Voyaging by sailing and paddling canoes for subsistence, ritual, trade and pleasure remains central to the lives of most Louisiade peoples.” Lepowsky 1995:52–53

Introduction

The Louisiade Archipelago is a group of volcanic and coral islands located in the southeast of Milne Bay Province, Papua New Guinea (Fig.1). Many islands are small (less than 10 km²), and their inhabitants have traditionally relied on subsistence fishing and agriculture for food security. Incomes are very low, with average annual household income estimated at approximately USD 130. Cash is sought after (Kinch 2001), and is needed to pay school fees, buy foodstuffs, and pay for health care, and is also beginning to be used to meet traditional obligations. Sources of cash income vary, but in recent years beche-de-mer has become a pri-

mary income source for inhabitants of some of the smallest and most marine-dependant islands (Kinch 2001; 2002a).

Residents in the more remote islands of the archipelago (in particular the islands in Deboyne Lagoon and the Calvados Chain) rely heavily at present on sailing canoes (*sailau* in the local Misima language) as a basic means of transport (Fig. 2). Sailing canoes are used to move between islands³, to transport goods and cargo, to access fishing grounds, and when engaging in trading, mortuary obligations and exchange⁴. The planked canoes vary in length from 4–12 m and carry a single outrigger. The larger canoes are substantial,



Figure 1. Louisiade Archipelago. (M. Smaalders)

1. Mark Smaalders, BPD5, 98848 Noumea Cedex, New Caledonia. Email: mark@smaalders.net.
2. Jeff Kinch, Conservation International, PO Box 804, Alotau, Milne Bay Province, Papua New Guinea. Email: j.kinch@conservation.org
3. Owing to land and/or water shortages, some inhabitants of the small islands in the Calvados chain are forced to live on one island and garden on another; transport between garden and home is typically by sailing canoe. The most extreme example may be Sabarl (or Sabara) Island, which has virtually neither topsoil nor freshwater (Battaglia 1983); islanders maintain gardens on Hemenaha (3 km away) or Pana Tinani islands (some 6 km distant).
4. Both ceremonial and subsistence goods are commonly exchanged. A survey conducted in 1999–2000 in the western portion of Milne Bay found that 65% of households had gone trading in the preceding six months (Kinch 2001).

seaworthy craft, able to carry five or more crew plus freight, and are capable of long-distance voyages when handled by experienced sailors.

Although many islanders are able sailors, fewer are skilled canoe builders. Most islanders obtain their canoes from expert canoe builders through complex social exchanges, with the larger canoes in particular representing significant investments. Cash as well as subsistence and ceremonial goods are typically involved in an exchange.

Growing populations, reduced government expenditures and expanding individual expectations are increasing the pressure on islanders to accumulate cash. At the same time, market prices for selected marine resources (such as beche-de-mer) are rising; and as a result, islanders are increasingly turning to them to earn cash. Stocks of some beche-de-mer species and other marine invertebrates are becoming locally scarce (Kinch 2001). Local exporting companies have begun offering credit schemes to islanders to purchase motorised dinghies. These allow islanders to venture farther afield in search of high value resources, to make more frequent harvesting trips (including when winds are absent or very light), and to harvest in previously inaccessible areas (such as those with particularly swift currents). As a consequence, over the last two to three years there has been a rapid increase in the purchase of dinghies. The outcomes of this ongoing technological change are as yet uncertain, but if dinghies replace sailing canoes as the primary means of transport, results are likely to include an erosion of traditional knowledge relating to canoe building and sailing, significant social and cultural changes, and an increase in harvesting pressure on commercial marine resources.



Figure 2. *Sailaus* in Deboyne Lagoon. (M. Smaalders 1997)



Figure 3. Canoe builder and Normanby-based buyer. (M. Smaalders 1997)

Canoe design and construction

Most canoes built in the islands are constructed on Panaeati Island (within Deboyne Lagoon), a regional canoe building centre for at least 100 years (see Haddon and Hornell 1975). Gawa Island serves the same function in northern Milne Bay (Hide et al. 1994). Some canoes are built for use by Panaeati residents, but many are destined for other islands (primarily the small islands of the Calvados Chain and neighbouring Vanatinai, or Sudest Island). Canoe builders on Panaeati indicated that canoes were also traded with residents of Normanby (Duau) and adjacent islands

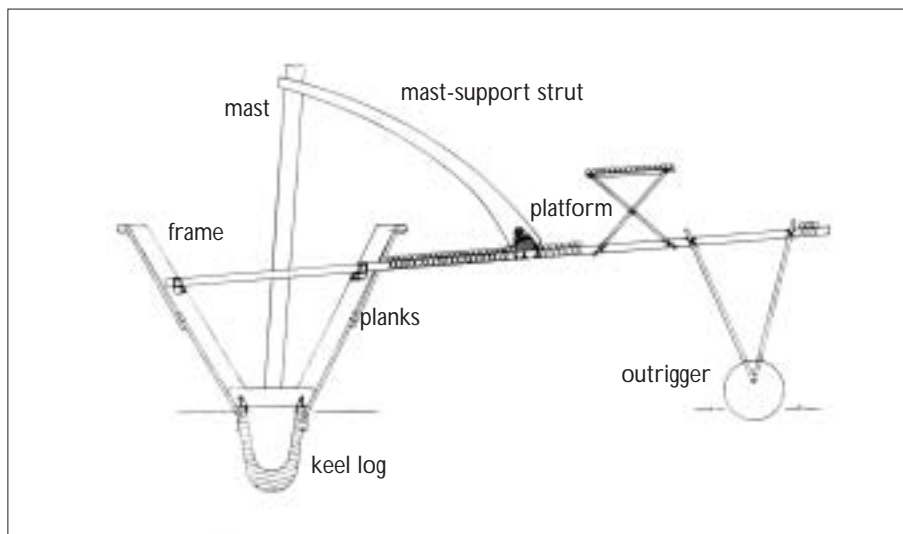

Figure 4. Canoe cross section. (M. Smaalders)

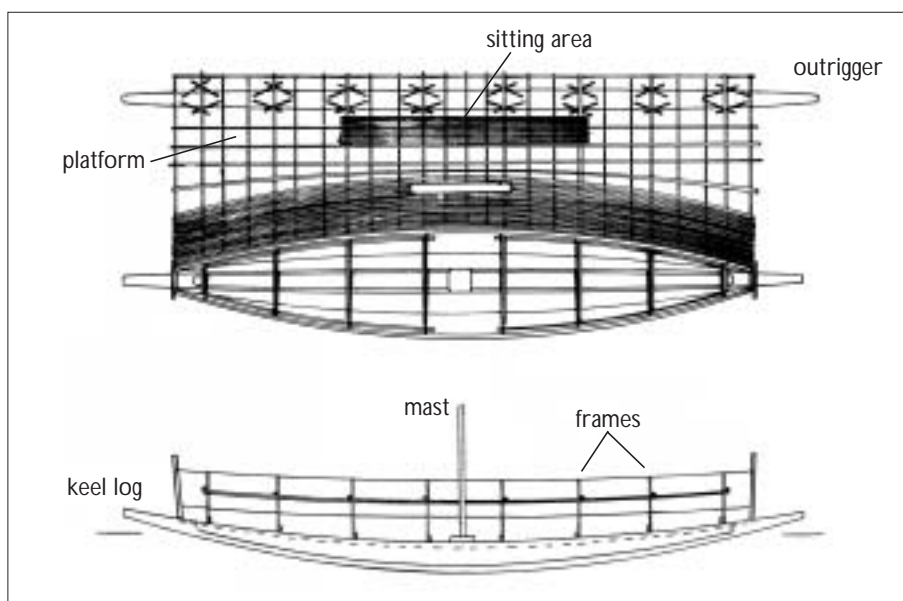

Figure 5. Canoe plan and profile. (M. Smaalders)

(Fig. 3). In 1997 there were some 20 expert canoe builders on Panaeati (Weda Gaunedi, Panaeati canoe builder, 1997, pers. comm.).

Louisiade Archipelago sailing canoes are all of a similar design, with a single, planked deep-V hull balanced by an outrigger (Figs. 4 and 5). They are rigged and sailed as proas, which reverse ends (bow becomes stern) when changing direction (called shunting rather than tacking). The outrigger is always kept to windward.

Canoes are typically measured by outstretched arm-length, with a “five-arm” canoe approximately 9-m long⁵. The width of the main hull on a 7-m canoe is about 1.2 m. The overall width of such a canoe is approximately 3 m.

The wood used for canoe construction on Panaeati is *Calophyllum inophyllum*, known in the Misima language (spoken on Panaeati) as *malauwi*. *C. inophyllum* grows in the interior of the island, and on Panaeati it is used exclusively for canoe building

5. The sailing canoes in use in the archipelago are classed by size as follows: *sailau dory* (length 5.3 m–6.4 m, hull width 0.85 m–1.0 m, overall beam 2.15 m–2.65 m); *sailau* (length 7.0 m–8.4 m, hull width 1.05 m–1.35 m, overall beam 2.7 m–3.35 m); and *sailau bwabwatana* (length 8.9 m–10.2 m, hull width 1.25 m–1.4 m, overall width 3.3 m–3.6 m).

Canoes are typically constructed from two *malauwi* trees: one with a curved stem forms the main hull's keel log while a straight tree is selected to furnish the planks that are fastened atop the keel. The keel log portion of the canoe is a true dugout, being carved from one tree and hollowed inside (Fig. 6). In profile, the keel log is carved into a graceful, tapering arc. Frames are fashioned from *malauwi* (shaped in a modified V) and positioned atop the keel log. Once frames are shaped, holes are drilled in the lower legs, with corresponding holes in the inside of the keel log. Vine or, more typically, small diameter synthetic line is used to lash the frames to the keel log. An 8-m canoe would typically have eight frames (Fig. 7).

Four planks are cut from the second log (on larger canoes these may be 60 cm wide and 10.5 m long); they are tapered in thickness from about 32 mm in the centre to 12 mm at the ends (Figs. 8 and 9). Traditionally, planks are lashed to both frames and keel, but today most builders use copper nails in conjunction with the lashings.

Light, round beams about 35 mm in diameter join the hull and outrigger, with one beam adjacent to each frame. These are lashed to round longitudinal stringers fitted inside the hull. The outrigger, fashioned from a single debarked breadfruit log, is joined to the outboard end of the beams by crossed sticks inserted into holes in the outrigger and lashed to the beams. Slender sticks (of *aipapak-ena*) are lashed atop the beams to form a platform between the hull and outrigger. The final result is

a strong but flexible construction that places no loads on the hull planks.

The canoes are rigged with a dipping-lug sail, using bamboo for the boom and yard (Fig. 10). The sails are made from a variety of materials: plastic sheeting, tarps and old Dacron yacht sails (obtained through exchange with visiting yachts) are all common (pers. obs.). The dipping-lug rig was apparently inspired by Australian pearl lug-



Figure 6. Hollowed-out keel log. (M. Smaalders 1997)



Figure 7. Keel log with frames attached, and first plank being fitted. (M. Smaalders 1997)



Figure 8. Initial work on planks is done in the bush with an adze. (M. Smaalders 1997)



Figure 9. Final smoothing of hull planks with hand planes. (M. Smaalders 1997)



Figure 10. All Louisiade canoes are fitted with dipping-lug rigs. (M. Smaalders 1997)

gers⁶. The mast, shaped from a small tree, is canted toward the outrigger (i.e. to windward), with four shrouds led to the far edge of the platform. A curved strut, forked at both ends, is inserted

between the mast and a sturdy longitudinal beam atop the platform. Wooden blocks can be inserted to adjust the mast: light winds call for the mast to be nearly upright, whereas in stronger winds the mast is angled increasingly into the wind. Increasing the rake has the effect of reducing the projected sail area, and generates lift in strong winds.

The helmsman sits on the platform at the stern of the canoe, with one foot on the end of the keel log, the top of which is flattened. A large paddle is used for steering; raising and lowering the paddle alters the course relative to the wind. To make small course adjustments the paddle is twisted, which brings the trailing edge away from the keel log. Under sail the canoes are well balanced and generally easily handled⁷.

Trade and exchange in canoe building

The process of constructing a canoe is typically lengthy, in part to allow the logs and planks to slowly dry, but also as a result of the complex system of trade and exchange that operates in the islands. Work on a canoe often comes to a halt once the keel log and planks have been moved from the bush; many planks and keel logs can be seen stored beneath houses on Panaeati. The delay before construction recommences may last for months or even years. Builders constructing a canoe for their own use may lack either time or resources to proceed with construction, whereas those who have contracted with a builder may need to accumulate cash, trade goods or ceremonial valuables⁸.

When builders trade canoes with other islanders the exchange often involves ceremonial valuables (e.g. shell-disk necklaces and greenstone axe blades), in addition to practical goods (plates and clay pots) and food items such as pigs, yams and sago (Lepowsky 1983; Kinch 2001). The terms of

6. A Panaeati canoe builder indicated that the *sailau* rig was copied from Australian pearl luggers, which were active in the Milne Bay area as late as the 1950s (Weda Gaunedi 1997, pers. comm.). Berde (1983) indicates a Brooker islander developed the *sailau* design while labouring in Queensland sugar fields early in the last century; it is likely that he would have likely seen pearl luggers and other similarly rigged coastal craft in use; the design spread from Brooker to Panaeati in the 1930s.
7. Small canoes are easily steered once the principles are understood; larger canoes require significantly more skill to handle, especially in rough weather.
8. Typically, very little cash is expended to obtain the materials for the canoe. Local residents pay five kina (about USD 1.30) to the local community for each tree felled, and a few kina are spent on a handful of copper nails. In addition, materials for the lugsail must often be purchased with cash. More importantly, a builder's workers and guests must be fed, which requires that either the builder himself or the buyer amass significant surpluses through family or clan relationships.

exchange for a canoe vary with the size, the prospective buyer's relationship to the canoe builder, and what the buyer has to trade. Canoes may also form the bride price that a groom must pay to the bride's family, or be payment to a traditional landowner for a house site in a village (Levi Arthur, Panaeati canoe builder, 1997 pers. comm.). In some instances exchanges are complex, with valuables being obtained from a number of third parties (Kinch 1999); some valuables are passed down through mortuary feasts (Lepowsky 1995).

Canoe construction itself also involves an exchange. When initially constructed, Panaeati canoes are fitted with temporary (albeit well-finished) outriggers, typically fashioned from a breadfruit tree. When the canoe is complete, the builder will set out on a maiden voyage, bound for Normanby, Suau or Basilaki Island. The builder carries with him yams or other goods, and these are traded for a tree (*vihowan*) that is lighter than the original breadfruit. Using tools carried in the canoe, the builder fashions a new outrigger, and the canoe is then sailed back to Panaeati, or on to another island, if it is to be traded. Thus, even before they are completed, the canoes enter the trade system.

The broader exchange network

The exchange network in the Louisiades involves both subsistence and prestige trade goods, and has been characterised as a very practical response to the resource shortages facing the inhabitants of these small islands (Lepowsky 1983; Kinch 2001). Edible trade items include fish, turtles and eggs, clams, Nicobar pigeons, shellfish, yams, sago, bananas, taro, betelnut and mustard; money and store goods (e.g. tobacco, rice and sugar) are often part of exchanges as well (Kinch 1999). European visitors to the islands (a number arrive every year on sailing yachts) are readily drawn in to exchanges, with used Dacron yacht sails, rope, needles (to repair sails), clothes, fabric, magazines and books all in demand (pers. obs.). Trading voyages are most frequent between the islands of the eastern Louisiades (especially the Calvados Chain, but also Sudest Island, the Deboyne Islands, and Misima Island); Ware, Tubetube, Normanby and Kwairawa are also visited.

As islanders' needs evolve, the specifics of the exchange networks and the goods traded have altered. Exchange continued and even expanded following pacification, despite disapproval by



Figure 11. A *sailau* and motorised dinghies share the beach at Enivala (Punawan) Island. (J. Kinch 2002)

missionaries and the colonial government. Exchange networks have provided islanders with a higher standard of living than would otherwise be available, have promoted the development of regional specialisation, and encouraged the production of surplus (in the form of garden produce, practical goods such as pots and canoes, and ceremonial items). Exchange voyages have been very efficient means of distributing these surpluses among islands and clans, have expanded islanders' social networks and cultural contacts, and facilitated the distribution of ideas and customs (Lepowsky 1983). Canoes and the exchange networks that they make possible "weave remote communities into webs of social ties that facilitate a higher standard of living, a richer social life, chances at treasure and fame, and the means to honour religious obligations" (Lepowsky 1995:52).

Evolution in marine transport

Sailing canoes have been the primary means of transport for islanders for hundreds of years, but this situation may soon change due to a rapid increase in the number of motorised dinghies. The demand for sailing canoes has increased on at least some islands over the last 30 years, while the last few years have seen a dramatic increase in the acquisition of motorised dinghies (Fig. 11). In 1971 Berde found 11 sailing canoes on Brooker (see Kinch 1999), while in the late-1970s Lepowsky (1983) found 11 canoes in use on Grass Island (whose population then numbered 200). By 1999, Kinch (1999) counted 50 sailing canoes in use on Brooker, with many households owning or having access to one or more canoes; in late-2002 there were 38 sailing canoes at Brooker, and canoes were being actively exchanged to the east with

residents of Sudest Island and various islands in the east Calvados).

The use of dinghies is a very recent phenomenon. In 1997, few islands had more than one motorised dinghy. In February 1999, Brooker Island still had just one motorised dinghy in use (Kinch 1999). The number increased to three later that year (Kinch 2001). By early 2001 the number had reached 12 (Kinch 2001), and by September 2002 there were 17 dinghies on Brooker Island (Jeff Kinch, pers. obs.).

The number of canoes under construction during the same 30-year period has decreased significantly. In 1971 Berde recorded over 40 sailing canoes under construction on Panaeati, and similar figures were reported in 1994 (Hall et al. 1994). In 1997 there were about 20 canoes at some stage of construction (Mark Smaalders, pers. obs.). By 1999 that number had dropped to nine (Kinch 2001).

Brooker islanders have historically made greater use of sailing canoes than have residents of some of the larger islands, owing to their greater reliance on marine resources and trade, but the dramatic increase in canoe usage over the last two decades appears unprecedented. It may partly be the result of an increase in population, but it is likely that commercialisation of marine resources (with the attendant opportunity to earn cash, which is increasingly in demand) has also played a role. The latter is directly responsible for the recent and very rapid turn to motorised dinghies, which allow islanders to harvest greater quantities of beche-de-mer (or other marine resources), from a larger area, in a shorter amount of time (Kinch 2001). There are indications that the widespread adoption of motorised dinghies on Brooker may be in part a move by islanders to avoid being disadvantaged, in what might be likened to a transport “arms race”. Islanders have indicated that motorised dinghies allowed some people to increase their harvest of marine resources and thus make more money; this was viewed as unfair, and led many more islanders to invest in dinghies (Jeff Kinch, pers. obs.).

The decrease in canoe construction observed during the late-1990s may be the result of an increased desire for motorised dinghies, though reduced availability of *C. inophyllum* may also have played

a role (Kinch 2001). In 1997, canoe builders and sailors on Panaeati expressed concern over the sustainability of *malauwi* harvesting, and over the increasing practice of building canoes for cash, rather than traditional exchange (Weda Gaunedi 1997, pers. comm.). Efforts to control the trade relied on an additional levy for each *malauwi* tree felled, if canoes were built for non-residents of the Deboyne Islands. Non-residents paid 50 kina, as opposed to the five kina resident fee, but most purchasers evade the higher fee because they have a relative on Panaeati.

Marine resource use and conservation in Milne Bay

The marine ecosystem of Milne Bay (including the waters around the Louisiade Archipelago) has been identified by recent surveys as being among the world’s most ecologically diverse and pristine, displaying high levels of endemism and supporting large populations of threatened species (Global Environment Facility 2002). This environment has also been identified as being at risk of degradation, a matter considered of global concern owing to the area’s extremely high levels of marine biodiversity (Filer 2002). A number of islands (45) within Milne Bay have been identified as “small islands in peril” because of a combination of high population density and dependence on subsistence resources from a limited area⁹.

As is true in much of the Pacific region, marine resource use in the Louisiade Islands is artisanal in nature, providing for subsistence needs as well as limited small-scale commercial production. Because of a lack of regularly scheduled cargo transport and the absence of refrigeration facilities, commercial harvesting primarily targets non-perishable, high-value invertebrate products. Residents of some of the smaller islands are especially dependent on income from harvesting resources such as beche-de-mer, with the cash thus generated used for basic necessities, feasts and other social obligations, education, and church contributions¹⁰ (Kinch 1999; 2001). Residents of the larger islands within the eastern Louisiades (such as Rossel and Sudest) are generally less dependant on the commercial harvesting of marine resources, relying also on pigs, betel nut, copra, and traditional valuables such as shell necklaces (*bagi*) as income sources (Hide et al.

9. “Small islands in peril” are defined to include those with less than 100 km² of cultivable land and a population in excess of 100 persons per square kilometre of cultivable land, where the population depends primarily on subsistence activities for survival, and lacks rights of access to subsistence resources on or around other islands sufficient to moderate this level of population pressure. Fully 44 of Milne Bay’s “small islands in peril” are “very small islands in peril”, as their cultivable land area is between 1–10 km² (Filer 2002).

10. Beche-de-mer alone accounted for just under half of Brooker residents’ earnings between July 1998 and June 1999; most of the remainder was acquired through harvesting trochus, crayfish, fish and giant clam (Kinch 1999).

1994). The approach taken by the inhabitants of the larger islands is perhaps more typical of Pacific Islanders generally, who tend to treat shallow water invertebrate fisheries as a source of “windfall” cash, rather than a dependable income source (Dalzell et al 1996).

The inhabitants of the smaller Louisiade islands differentiate between subsistence and commercial fishing activities. The two activities are kept distinct in the minds of islanders, who are more prone to restrict outsiders’ access to fishing grounds if commercial species are being targeted than if the object is a subsistence catch. Kinch (1999; 2001) documents a number of instances of conflict over access to fishing grounds, primarily involving commercial species, but also in cases of invertebrates used in the manufacture of trade goods with ceremonial value (i.e. *bagi*).

Studies in Milne Bay Province indicate that there has been an impact on both the abundance and diversity of selected marine species through small-scale commercial harvesting, including more valuable beche-de-mer species (Kinch 2001; 2002a), and giant clams (densities in the province are estimated to have declined by over 80% from their pre-commercial harvesting levels [Kinch 2002b]). Declines in giant clam abundance have a direct impact on food security, as these are an important subsistence food source.

The pattern of rapid overexploitation of resources by artisanal fishers is not new. Historically the beche-de-mer fishery in the South Pacific has been cyclic, with periods of heavy exploitation followed by much reduced pressure; during the latter period the resource may recover. Small-scale commercial fisheries generally are of a “sporadic, boom and bust” nature (Adams and Dalzell 1994:1), and have been characterised as being particularly prone to overharvesting (Dalzell et al. 1996). The current beche-de-mer boom in the Pacific Islands began in the mid-1980s, and has continued, despite declining stocks, owing to high demand in Asia, which has been termed “apparently insatiable” (Dalzell et al. 1996:75).

To address the potential degradation of the marine environment, resulting from both subsistence and small-scale commercial harvesting, the Milne Bay Community-based Coastal and Marine Conservation Program (MBCP) is being imple-

mented by a number of partner organisations¹¹. The aim is to establish Locally Managed Marine Areas in selected areas; marine use policy changes covering all of Milne Bay Province and capacity-building at the local and community level are also planned. The goal of these efforts is recovery of currently overharvested species (such as giant clams), and prevent overexploitation of other marine species owing to population increase or development of new markets (Global Environment Facility 2002; Kinch 2002b).

Canoes and sustainable lifestyles

The subsistence lifestyle of the inhabitants of the smaller islands of the Louisiade Archipelago has depended directly on a marine transport system that is sustainable with minimal cash inputs. The sailing canoes described here are one aspect of a system that has been in use for generations. This system also incorporates and depends on other elements. These include the social and exchange networks that support canoe construction and assist in distributing canoes throughout the archipelago, the trade networks that help to bring benefits and status to canoe owners, and the maintenance of specialised knowledge by canoe builders and sailors. Cash inputs into this system have historically been relatively minor (though cash has become an increasingly important component of canoe purchases), but other commitments are significant. Canoes generally represent a significant investment of subsistence and/or ceremonial goods, and maintenance of the other elements of the system requires a considerable time commitment. The system is thus a costly one, but the cost has been borne in subsistence terms, on a generally sustainable basis: the use and construction of sailing canoes has not placed significant pressure on either subsistence or commercial marine resources¹².

The elements of the system are mutually interdependent, with the low cost (in cash terms) of maritime transport in the islands allowing Louisiade islanders to maintain their trade and exchange network. The exchange network, in turn, contributes to food security, and serves to distribute risk from natural events (such as droughts and cyclones) between or among islands, with residents of smaller islands able to obtain yams and other foods from trading partners on larger islands. Louisiade islanders have recognised the

11. Partners include the provincial government, national government, United Nations Development Program, Global Environment Facility, and Conservation International.

12. The canoes can be seen as a form of physical capital, which allow islanders to access natural capital (marine resources), and maintain their social capital (exchange networks) and cultural capital (values and belief systems); there is also human capital involved (building and sailing the canoes requires specialised knowledge, and exchange networks encourage other specialisation to be retained). In contrast motorised dinghies require primarily just financial capital. See Lal and Keen (2002).

value of their trade and exchange systems, and have continued to build canoes and maintained their inter-island exchange, feasting and visiting networks despite significant efforts by colonial and national governments, missionaries and traders to put an end to these activities. In fact, the act of continuing to practice these customs can be seen as an overt act of resistance by islanders to external control, and an affirmation of cultural autonomy and personal identity (Lepowsky 1995).

Replacement of sailing canoes with motorised craft has clearly begun, on both Brooker Island and in western Milne Bay¹³. If this trend continues¹⁴ and spreads to additional islands, such a shift may have significant implications for both subsistence lifestyles and marine conservation. Although dinghies will not provide greater absolute range than the larger sailing canoes, they will enable fishermen to cover more area in a given amount of time. They may thus contribute to an increase in fishing pressure, and to increased exploitation of resources in remote locations. In addition, motorised craft require significant and continuing cash inputs (including payments for the boat and maintenance and fuel costs); the cost of an outboard in 2003 represented approximately 25 times the annual average household income¹⁵.

Fishers using dinghies must harvest a greater quantity of resources than do those using canoes, owing to the higher ongoing cash needs. One of the common mistakes in fisheries, in the Pacific region and elsewhere, is that fishers and money lenders are prone to estimate economic returns of a fishery based on initial catch rates, rather sustainable yields (which are generally much lower). The provision of easy credit and soft loans encourages over-capitalisation of fisheries, in which an excessive number of vessels compete for an often rapidly shrinking resource. The end result is that fishers either default on their loans, or start exploiting other resources (Dalzell et al 1996)¹⁶.

Conclusion

The increasing use of dinghies represents not simply a change from one type of boat to another, but a significant shift in the type of investment made by islanders. Sailing canoes depend on and support both social networks and specialised knowledge and skills; the canoes are an intrinsic part of a complex subsistence lifestyle. In contrast, the use of dinghies depends on the availability of credit and the ability to earn cash (for purchase payments, fuel, and maintenance). What appears to be a simple choice regarding transport — canoe vs dinghy — is actually a decision that is likely to have much broader significance. Islanders who choose to invest in dinghies will face a growing need for cash, and the dictates of the cash economy, rather than the requirements of social networks and trade relationships, are likely to have increasing influence over dinghy owners' decisions. While the use of sailing canoes has encouraged investment in other subsistence-oriented aspects of life, the use of dinghies is likely to hasten the movement toward a cash economy (by increasing both the ability to obtain and the need for cash), and to weaken islanders' social networks and specialisations¹⁷.

Dinghy use is also likely to lead to greater pressure on commercially harvestable marine resources in the Louisiade Archipelago. The potential for commercial overexploitation of marine resources in Milne Bay is significant, and even the canoe-based fishery has exceeded sustainable limits, as indicated by the above mentioned overharvesting of giant clam and beche-de-mer. Pressure on these resources can only increase with the introduction of motorised craft. The combination of increased range and increased cash needs also suggests that fishers with dinghies may target additional resources.

The lack of reliable, low-cost marine transport (for both fishing and transport of catch) represents a constraint to coastal fisheries development in

-
13. Brooker is one of the more marine-dependant of the small islands in the eastern Louisiades, and has the largest sea territory in Milne Bay; Brooker islanders are also perceived by neighbouring islanders as wealthy. Because they can access a large marine environment, they may have more incentive to make a move toward motorised dinghies than do residents of other islands.
 14. At present, sailing canoes are still heavily used on Brooker and other islands; a recent fuel shortage meant that sailing canoes were being used by Brooker islanders in preference to dinghies. This may lead to the development of a dual transport system — with islanders owning or having access to both dinghies and canoes, as several families already do — but the investments required are significant.
 15. A Brooker islander indicated that in early 2003 a new 30 hp outboard motor cost 12,000 kina (approximately USD 3250); fuel cost in 2002 was approximately 4.60 kina/litre (USD 1.25/litre). Some families/clans have earned large quantities of cash from beche-de-mer harvesting over the last several years; a Brooker family/clan earned 17,000 kina and purchased two dinghies; another is estimated to have made K 24,000.
 16. In contrast with the movement to motorised dinghies, past improvements in canoe technology (such as took place with the development of the sailau, and which would have resulted in improved handling and speed) did not materially affect the subsistence nature of the transport system that had been developed.
 17. Dinghies and motors represent a very large investment, and this may force many islanders to rely on their families and clans to help pay for the purchase. The assistance they will be seeking will again be in the form of cash, however, and the net result may be to cause an even larger group of people to become more cash-dependant.

much of the Pacific Islands region, but in Milne Bay (and possibly elsewhere) may have also served an unintended conservation role by making it difficult for islanders to exploit many species commercially. When such transport does become available, subsistence fishing may be transformed into commercial fishing almost overnight, often with negative effects in terms of local resource management, nutrition and food security (Preston 1997). There is also a heightened risk that fishers may look to destructive fishing practices, which are typically resorted to because of population growth exceeding the sustainable carrying capacity of a subsistence fishery, or because of commercial pressure (i.e. the presence of a particularly high value resource, and access to a market). Across the region, improvements in the fishing power of gear and growth of human populations have in many locations been paralleled by declines in stocks, catch rates and, in some cases, landed volume of reef fish (Dalzell et al. 1996).

The agencies and researchers involved in efforts to establish conservation and fishery management programs in Milne Bay (including the MBCP) would do well to examine closely the factors fuelling the move to motorised dinghies, the resultant changes in patterns of resource exploitation, and the impact on social networks. Given that the shift to dinghies is still in its infancy, it may be possible to develop creative management policies that help mitigate or prevent some of the many problems that have arisen in other locations as a consequence of technological change.

References

- Adams, T.J.H and P. Dalzell. 1994. Artisanal fishing. Paper presented at the East-West Center Workshop on Marine Biodiversity Issues in the Pacific Islands, University of Hawaii.
- Battagila, D. 1983. Syndromes of ceremonial exchange in the eastern Calvados: the view from Sabarl Island. p. 445–465. In: Leach, J.W. and E. Leach (eds.) *The kula: New perspectives on Massim exchange*. Cambridge: Cambridge University Press.
- Berde, S. 1983. The impact of colonialism on the economy of Panaeati. p. 431–443. In Leach, J.W. and E. Leach (eds). *The kula: New perspectives on Massim exchange*. Cambridge: Cambridge University Press.
- Dalzell, P., Adams, T.J.H. and Polunin, N.V.C. 1996. Coastal fisheries in the Pacific Islands. *Oceanography and Marine Biology: An Annual Review* 34:395–531.
- Filer, C. 2002. Small islands in peril in Milne Bay Province. Project description, Resource Management in Asia-Pacific Program, Research School of Pacific and Asian Studies, Australian National University. 26p. <http://rspas.anu.edu.au/rmap/Pages/Projects/smip-prodoc1.pdf> Retrieved from the Internet 28 January 2003.
- Global Environment Facility. 2002. Papua New Guinea: Community-based Coastal and Marine Conservation in Milne Bay Province. Project proposal submitted for approval, May 2002. 87p. http://www.gefweb.org/Documents/Council_Documents/GEF_C19/Papua_New_Guinea_Milne_Bay.pdf Retrieved from the Internet 28 January 2003.
- Haddon, A.C. and J. Hornell. 1975. *Canoes of Oceania*. Honolulu: Bishop Museum Press. 909 p.
- Hide, R.L., Bourke, R.M., Allen, B.J., Betitis, T., Fritsch, D., Grau, R., Kurika, L., Lowes, E., Mitchell, D.K., Rangai, S.S., Sakiasi, M., Sem, G. and Suma, B. 1994. Milne Bay Province: Text Summaries, Maps, Code Lists and Village Identification. Agricultural Systems of Papua New Guinea Working Paper No. 6. Department of Human Geography, Australian National University, Canberra. <http://rspas.anu.edu.au/lmg/masp/search.php> Text retrieved from the Internet, 28 January 2003.
- Kinch, J. 2002a. Overview of the beche-de-mer fishery in Milne Bay Province, Papua New Guinea. SPC Beche-de-Mer Information Bulletin 17:2–16.
- Kinch, J. 2002b. Giant clams: Their status and trade in Milne Bay Province, Papua New Guinea. *Traffic Bulletin* 19 (2):1–8.
- Kinch, J. 2001. Social feasibility study for the Milne Bay Community-Based Coastal and Marine Conservation Program. A report to the United Nations Milne Bay Community-Based Coastal and Marine Conservation Program, PNG/99/G41, Port Moresby, Papua New Guinea.
- Kinch, J. 1999. Economics and environment in island Melanesia: A general overview of resource use and livelihoods on Brooker Island in the Calvados Chain of the Louisiade Archipelago, Milne Bay Province, Papua New Guinea. A report prepared for Conservation International, Port Moresby, Papua New Guinea.
- Lal, P. and M. Keen. 2002. Economic considerations in community-based project planning and implementation. South Pacific Regional Environment Programme International Waters Programme Technical Report 2002/05.
- Lepowsky, M. 1995. Voyaging and cultural identity in the Louisiade Archipelago of Papua New Guinea. p. 34–54. In: Feinberg, R. (ed). *Seafaring in the contemporary Pacific*. DeKalb, Illinois: Northern Illinois University Press.
- Lepowsky, M. 1993. *Fruit of the motherland: Gender in an egalitarian society*. New York: Columbia University Press.

- Lepowsky, M. 1991. The way of the ancestors: Custom, innovation, and resistance. *Ethnology* 30(3):217–235.
- Lepowsky, M. 1983. Sudest island and the Louisiade archipelago in Masim exchange. p. 467–501. In: Leach, J.W. and E. Leach (eds). *The kula: New perspectives on Massim exchange*. Cambridge: Cambridge University Press.

- Murray, J.H.P. 1912. *Papua or British New Guinea*. London: T. Fisher Unwin.
- Preston, G.L. 1997. Review of fishery management issues and regimes in the Pacific Islands region. Report prepared for the South Pacific Regional Environment Programme, South Pacific Commission and South Pacific Forum Fisheries Agency. 72 p. Accessed from the Internet at: <http://www.spc.org.nc/coast-fish/Reports/Misc/GEF-GPA.pdf>



The coexistence of whaling and whale watching in a traditional whaling region: The case of Taiji, Wakayama Prefecture, Japan

Shio Segi¹

Introduction

The discussion about the relationship between whaling and whale watching is polarised. Anti-whaling groups believe these two activities cannot coexist, and continue to urge that whaling be ended, stressing the economic benefits to be obtained from the sustainable use of cetacean resources. Examples from the Dominican Republic, the Bahamas and other Caribbean locations (Hoyt 1999), and from Vava'u, Tonga (Orams 1999), attempt to demonstrate the superiority of whale watching.

In contrast, whaling groups, composed mainly of anthropologists, economists and sociologists, seek coexistence. They have sounded the alarm on socially and culturally negative impacts caused by converting from whaling to whale watching, and have demonstrated the arbitrariness and overestimation of anti-whaling groups' economic analysis and falsehood of their outcomes. However, both groups place value on economic effects to greater or lesser degree.

Whale watching has been conducted in 87 countries and territories worldwide, attracting over nine million boat- and land-based tourists annually. In 1988, the value of the global whale watching industry was an estimated USD 300 million and a further USD 1049 million was gained from indirect tourism expenditure (Hoyt 2000). Although these estimates are still disputed, it is

clear that the direct and indirect economic impacts of whale watching are extremely important. Further, about 100,000 tourists annually participate in domestic whale watching tours, and many more participate in tours overseas (Hoyt 2000).

Owing to IWC's commercial whaling moratorium, the local economies of Japanese whaling centres have been devastated and their societies disrupted by the exodus of young people in search of employment and careers; and, there is little prospect of change. Although Japan has campaigned for a resumption of whaling at IWC, the prospect for an increase in the coastal whale quota is bleak, to say nothing of full resumption.

Under these circumstances it has been thought that whale watching could become a fast growing tourist industry with a large potential to resuscitate the economies and societies of the traditional whaling communities. But so far no whale watching businesses have developed in traditional Japanese whaling communities.

In this article I examine the traditional whaling community of Taiji, in Wakayama Prefecture, to clarify why a whale watching industry has not developed in traditional whaling communities. I also examine the processes and factors regarding the coexistence of whale watching and whaling in the wider area of southern Wakayama Prefecture, and its application to other whaling communities.

1. School of Policy Studies, Kwansai Gakuin University, 2-1 Gakuen, Sanda, Hyogo Prefecture Japan 669-1337. Email: shioism@hcc5.bai.ne.jp